Evolution of CFD as a Tool for Chemical Engineering

Richard D. LaRoche

Fluent Inc.

Lebanon, New Hampshire, USA

CFD in Chemical Reaction Engineering IV

Barga, Italy

June 2005

richard.laroche@fluent.com

CFD in the Chemical Industry in the 90's

- **Early adopters**
 - **Chemical Process CFD Users Group**

- **Early Struggles**
 - **Geometry & mesh generation**
 - **Affordable fast, compute resources**
 - **Limited solver technologies**

Chemical Process CFD Users Group

North American group (1993-2000)

- **3M**
- **Air Products**
- **Argonne National Lab (USDOE)**
- **Bechtel**
- **BP Amoco**
- **Chemineer**
- **Chevron**
- **Cray**
- **Dow Chemical**
- **Dow Corning**
- **DuPont**
- **Eastman Chemical**
- **Eli Lilly**
- **Huntsman**
- **LIGHTNIN**
- **Mitsubishi Chemical-US**
- **NETL (USDOE)**
- **Nalco Chemical**
- **FuelTech**
- **National Institute of Standards & Technology (U.S. Dept. of Commerce)**
- **Phillips Petroleum**
- **Procter & Gamble**
- **Rohm & Haas**
- **Shell Oil -US**
- **UOP**

European CPCFD Users Group

Roster from June 1998 Meeting in Munich

**DSM Research, Netherlands
University College London, UK
Center for Advanced Studies, Italy
Bayer AG, Germany
Unilever, UK
CIRSEE Suez Lyonnaise des Eaux, France
BP Chemicals, UK
LIPE-GPI-INSAT, France
Tel-Tek, Norway
Schlumberger Cambridge, UK
Performance Fluid Dynamics, Ireland
TU-Darmstadt, Germany
Sintef, Norway
Bechtel, USA**

**Aalborg University Esbjerg, Denmark
Norwegian University of Science
Technical University of Szczecin,
Poland
ICI Chemical & Polymers, UK
Neste Oy, Finland
LIPE-GPI-INSAT, France
EniTechnologie, Italy
BHR Group Ltd., UK
British Steel, UK
Hoechst, Germany
Cray Research/Silicon Graphics**

Examples

- **Chemineer HEV Static Mixer**
 - Large Eddy Simulation (LES)
 - Coefficient of Variation (CoV) Comparison with Experimental Data (Etchells, Wadley & Fasano, Mixing XVII, 1999)

- **Stirred Tank**
 - Sliding Mesh & Multiple Reference Frame (MRF)
 - Lagrangian Particle Tracking with Turbulent Dispersion
 - Minye Liu (Procter & Gamble) and Clay Andreasen (Cray)
 - Blendtime Comparison with Experimental Data (Grenville et al., BHRG, 1992)

Chemineer HEV Static Mixer

- Experimental work at Lehigh U. (Gretta, et.al)

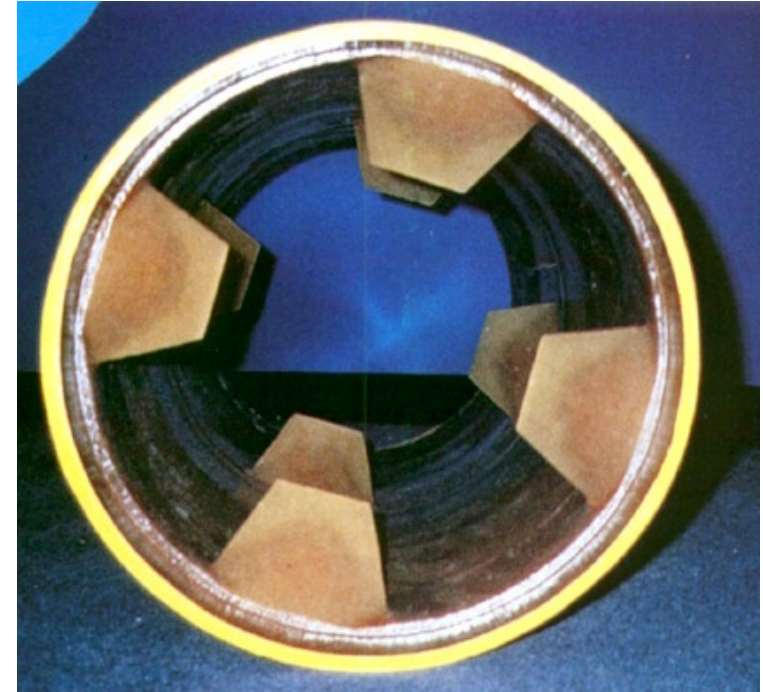
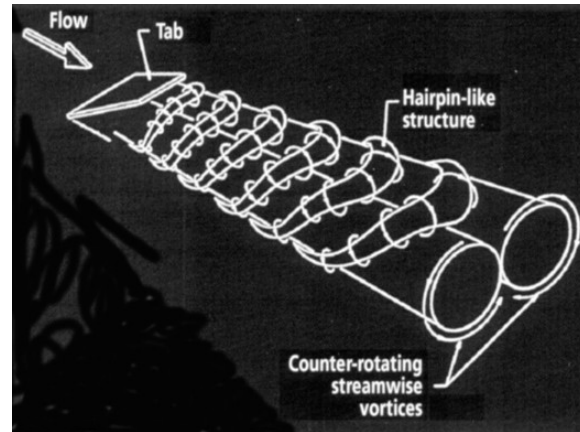

Photo Courtesy of Chemineer Inc.

- Steady-state $k-\epsilon$ (Bakker & LaRoche, Mixing XIV, 1993)
- Large Eddy Simulation (Bakker, 1998 AIChE Annual Meeting)
- LES with Experimental Verification (LaRoche & Etchells, Mixing XVII, 1999)

R.D. LaRoche , CFD in CRE IV
Barga, Italy, June 2005

HEV Mixer: Steady-State CFD Bakker & LaRoche (1993)

- **FLUENT v4.21**
- **400K cell structured grid**
- **k- ϵ turbulence model**
- **1/8 slide of 3D geometry**
- **9 CRAY C90 cpu hours**

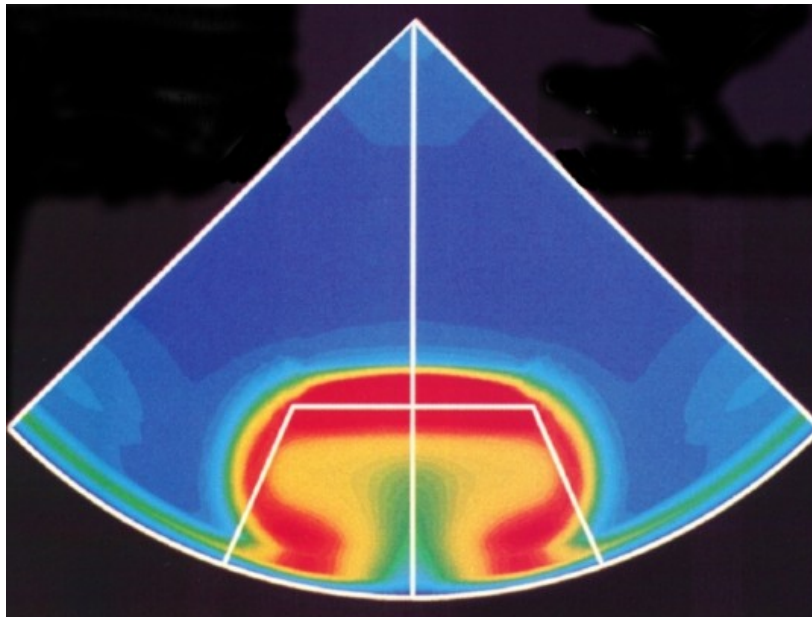

Turbulent K.E. past first tab

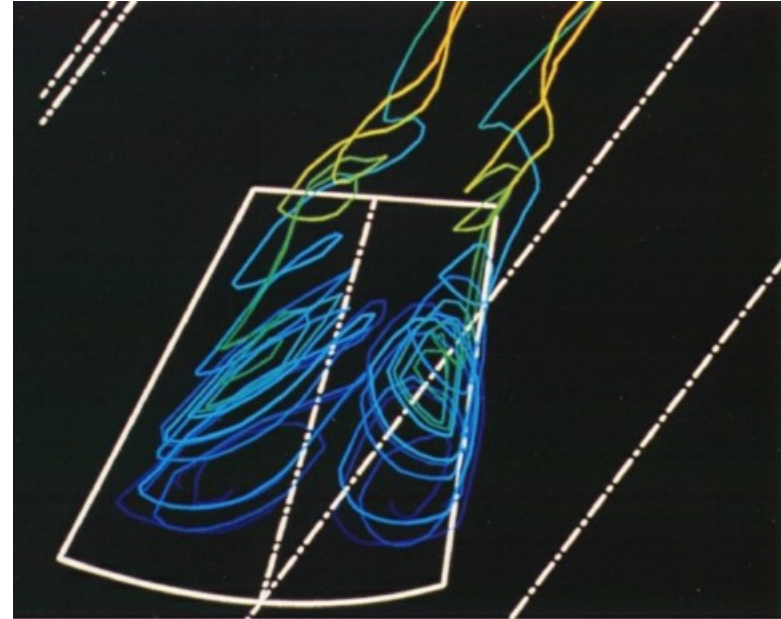

- **Qualitative results**
- **Difficult to converge**
- **Unable to predict mixing performance quantitatively**
- **Attempts with RSM model were not successful**

HEV Mixer: Large Eddy Simulation LaRoche & Etchells (1999-2000)

- **Work inspired by LES work by Bakker (1998)**
- **Follow-on work by Liu (2001-2002)**
- **3-array HEV**
 - **Re~200000**
- **Fluent v5**
 - **Unstructured Grid: 700-800K Tetrahedral Cells**
 - **LES model plus 2 species**
 - **100 timesteps**
 - **72 cpu-hours**
 - **18 wallclock hrs. (4 cpus)**
- **Verification with Experimental Mixing Performance Data**
 - **BHR Group, Cranfield, UK (1998-99)**

Effect of Gas Injection Scheme

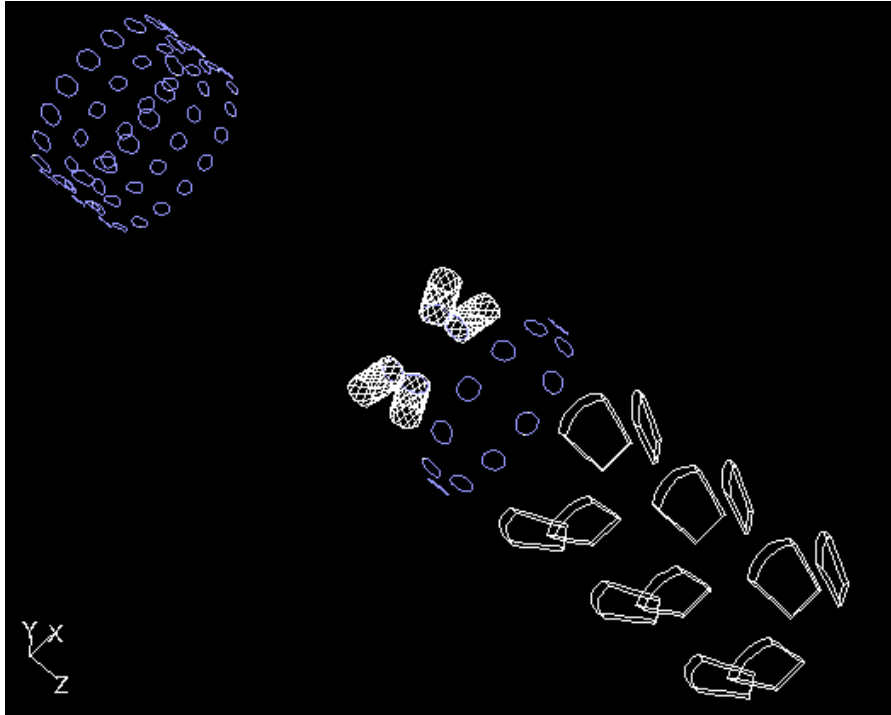

Base Case Injection

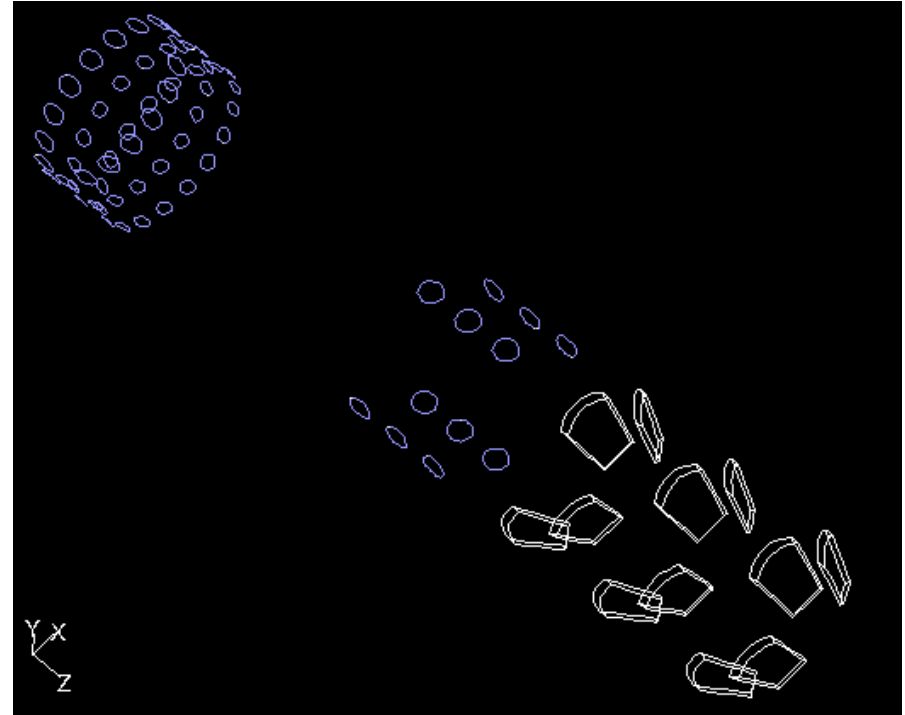

4-pt. Injection

HEV Static Mixer - Trailing Vortices

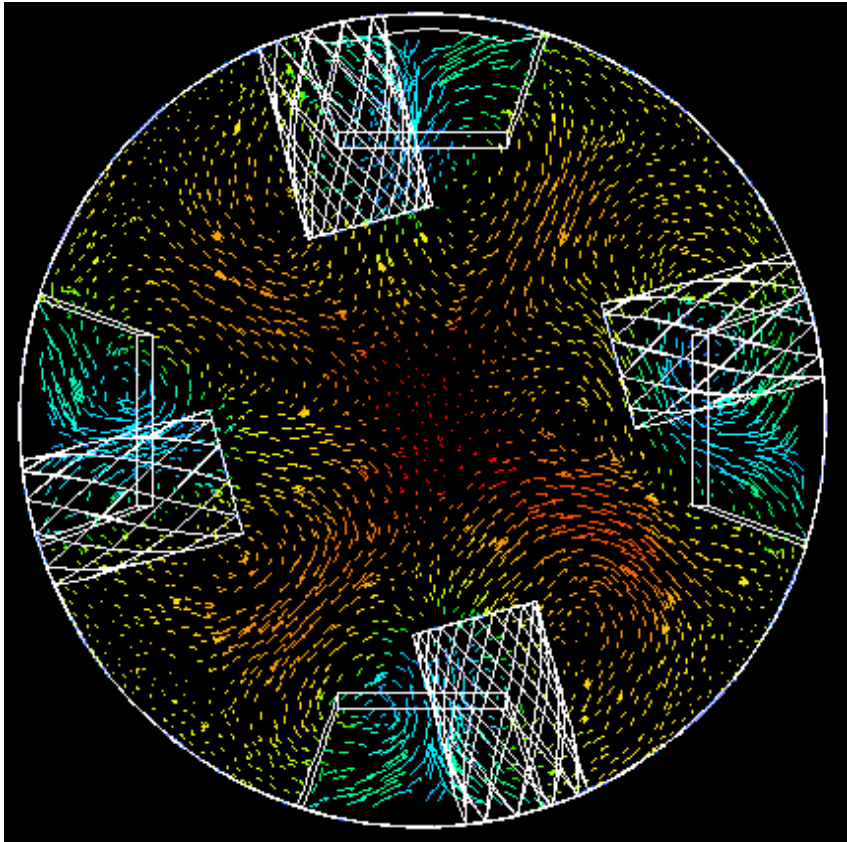

Base Case Injection

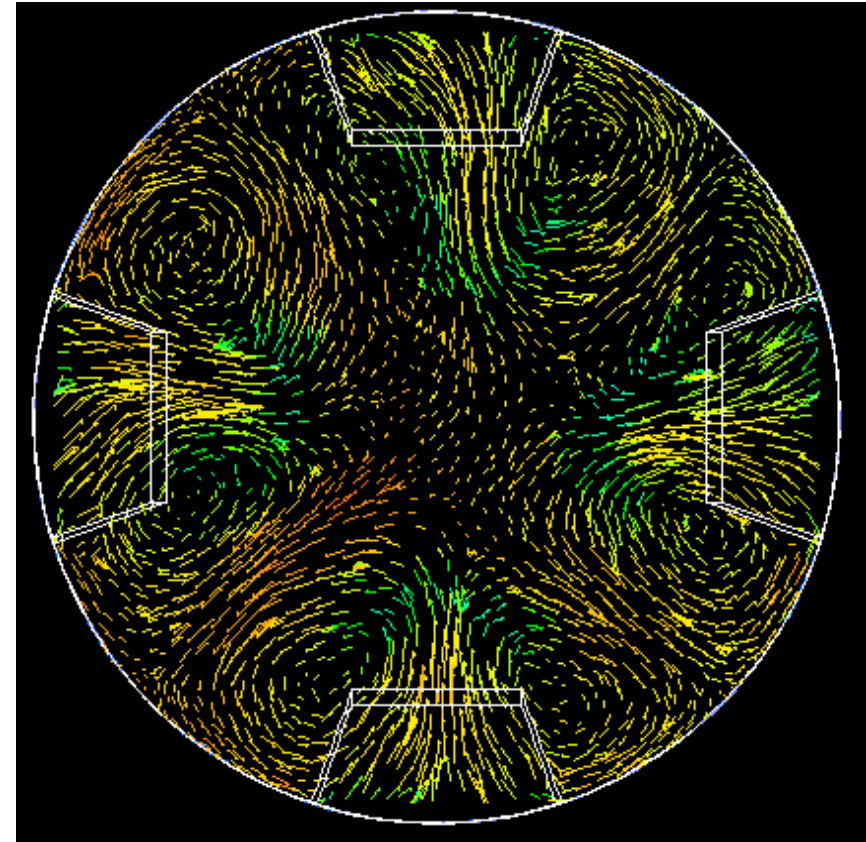

4-pt. Injection

Axial Concentration Profiles

- **Base Case Injection**

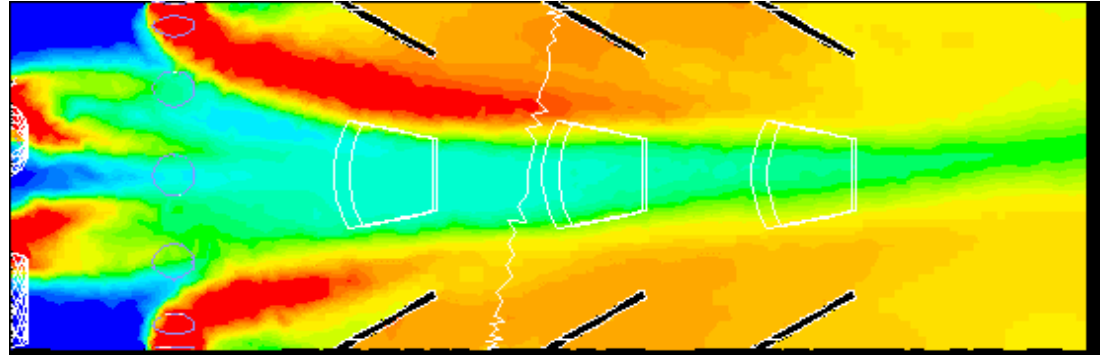

- **4-pt. Injection**

- Large diameter Inlets

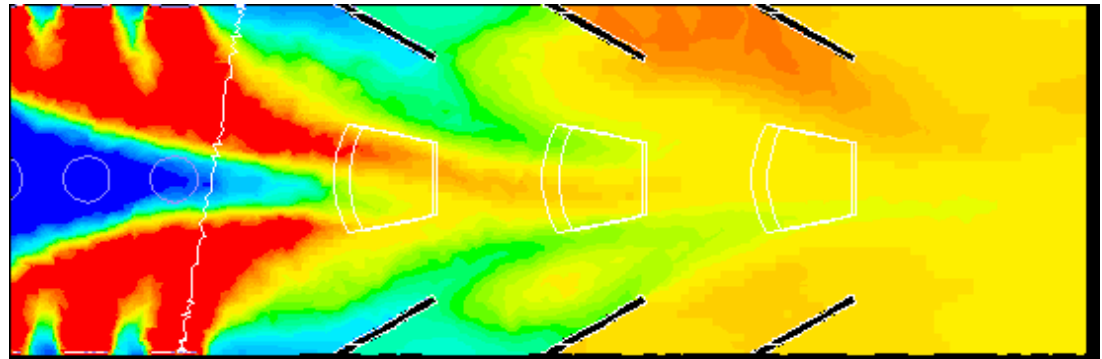

- **4-pt. Injection**

- Small diameter Inlets

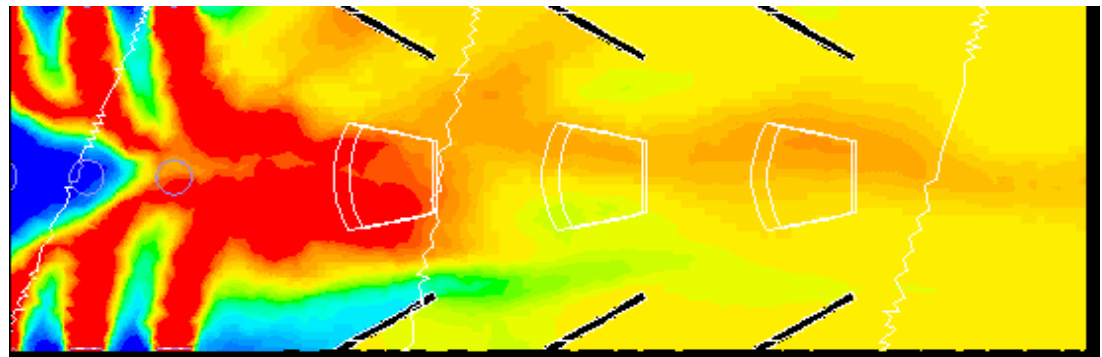

Note: Forney work used to size inlets

Trailing Vortices - 4-pt. Injection Cases

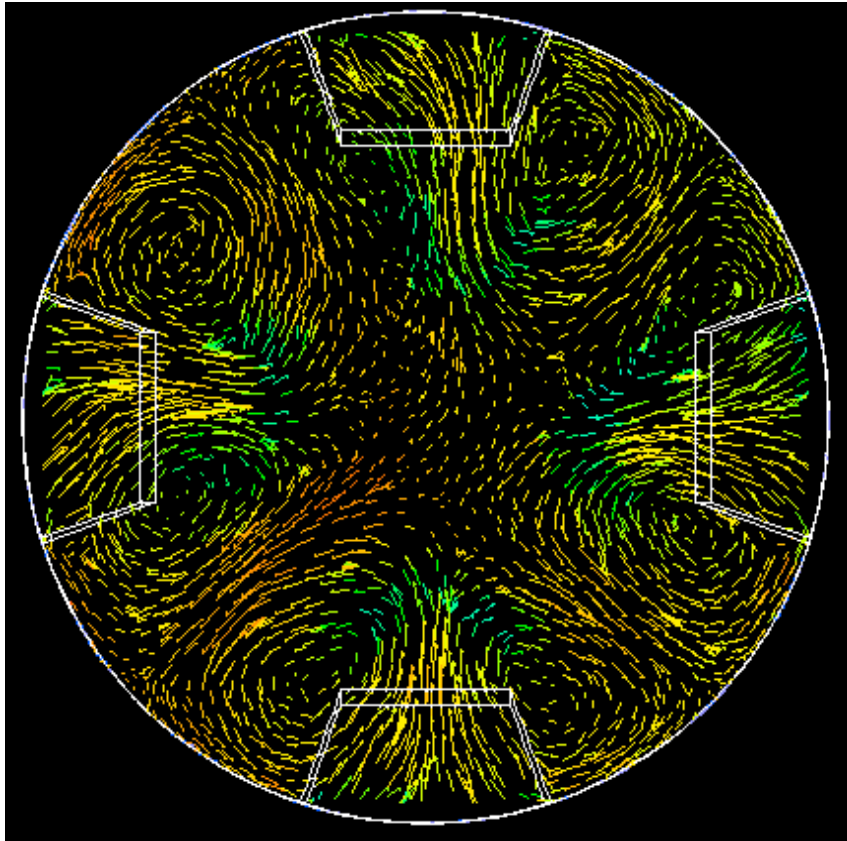

Large diameter Inlets

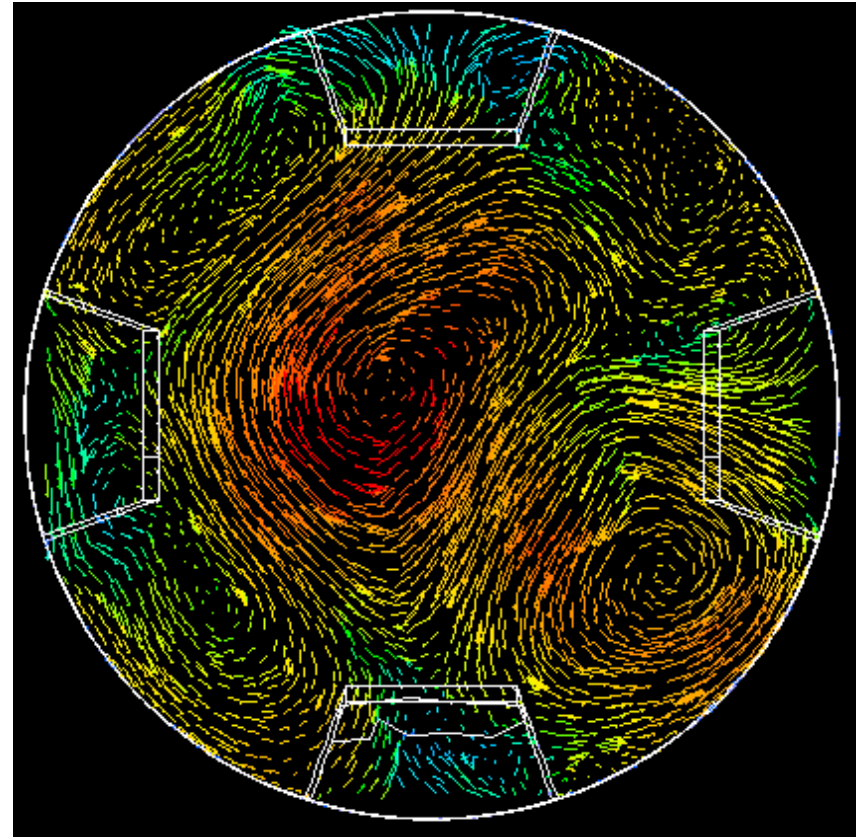

Small diameter Inlets

Comparison with Experimental Data

- **Coefficient of Variation**

$$CoV = \frac{\sigma}{\bar{x}} = \frac{1}{\bar{x}} \sqrt{\frac{\sum_{i=1}^n (x_i - \bar{x})^2}{n}}$$

- **Base Case Injection**

- **Experimental CoV=0.085 - 0.099**
- **Computational CoV=0.0810 ± 0.0050**

- **4-pt. Injection**

- **Experimental CoV=0.028 - 0.055**
- **Computational CoV=0.0405 ± 0.0137**

How Important Was This to DuPont?

JOURNAL ARTICLES BY FLUENT SOFTWARE USERS

JA151

Computer Simulation Yields \$1 Million at DuPont by Improving Static Mixing

By James N. Tilton
Sr. Consultant
DuPont Engineering Technology
Wilmington, DE

DuPont engineers used computer simulation to generate about \$1 million in increased yield at virtually no capital cost by improving static mixing upstream of a reactor. For this process, a Chemineer Kenics® HEV static mixer is used to combine two gaseous ingredients before they enter the reactor. Lower than expected yields led engineers to believe the ingredients were insufficiently mixed. They felt that more physical experiments would not provide enough insight into what was going on, and they did not want to embark on a costly, additional plant test program. Instead, DuPont engineer Richard LaRoche simulated the operation of the mixer using computational fluid dynamics (CFD) to examine flow patterns and species mixing. The results showed that two design features, each of which was

intended to improve mixing, were actually interfering with each other, preventing either from working effectively. Removing one of these features reduced the coefficient of variation, a measure of nonuniformity, at the exit of the mixer from 0.085 to 0.028, providing a significant increase in yield.

DuPont is a company that delivers science-based solutions that make a difference in people's lives in the areas of food and nutrition, health care, apparel, home and construction, electronics, and transportation. Last year the company had revenues of \$28.2 billion and a net income of \$2.3 billion. It has 93,000 employees of whom approximately 50% work outside of the United States. The company has more than 40

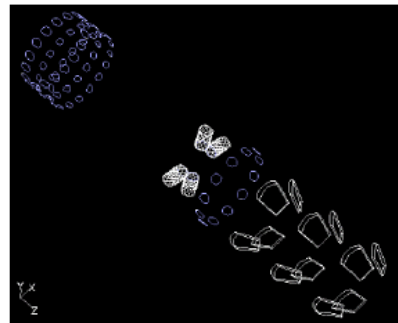

Base Case Injection

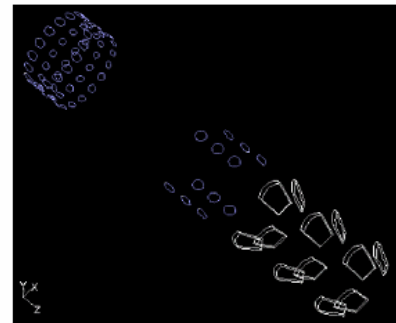

4-pt. Injection

Injection Geometries

Stirred Tank Flow

- Sliding-mesh CFD became commercially available in 1994-95
 - STAR-CD
 - FLUENT
 - CFX
- Prior CFD analysis only qualitative flow prediction
- Industrial collaboration to model time-dependent stirred tank flow (R. LaRoche, D. Choudhury, A. Bakker and CPCFD Users Group, 1994-96)
- Dow Chemical Laser-Doppler Velocimetry Data for 4-blade Pitched Blade Turbine (Cassian Lee, 1994)

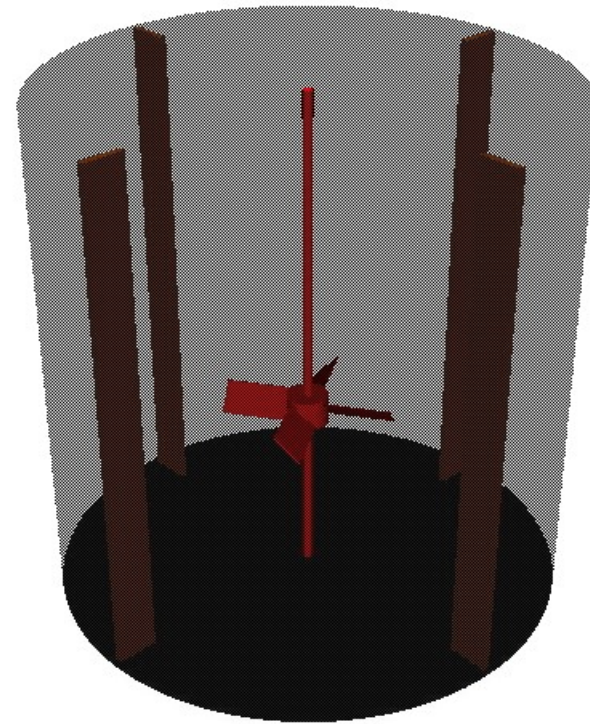

Stirred Tank Analysis (circa 1993) PBT/DT vs. PBT/PBT Configurations

(length and color by velocity magnitude in m/s)

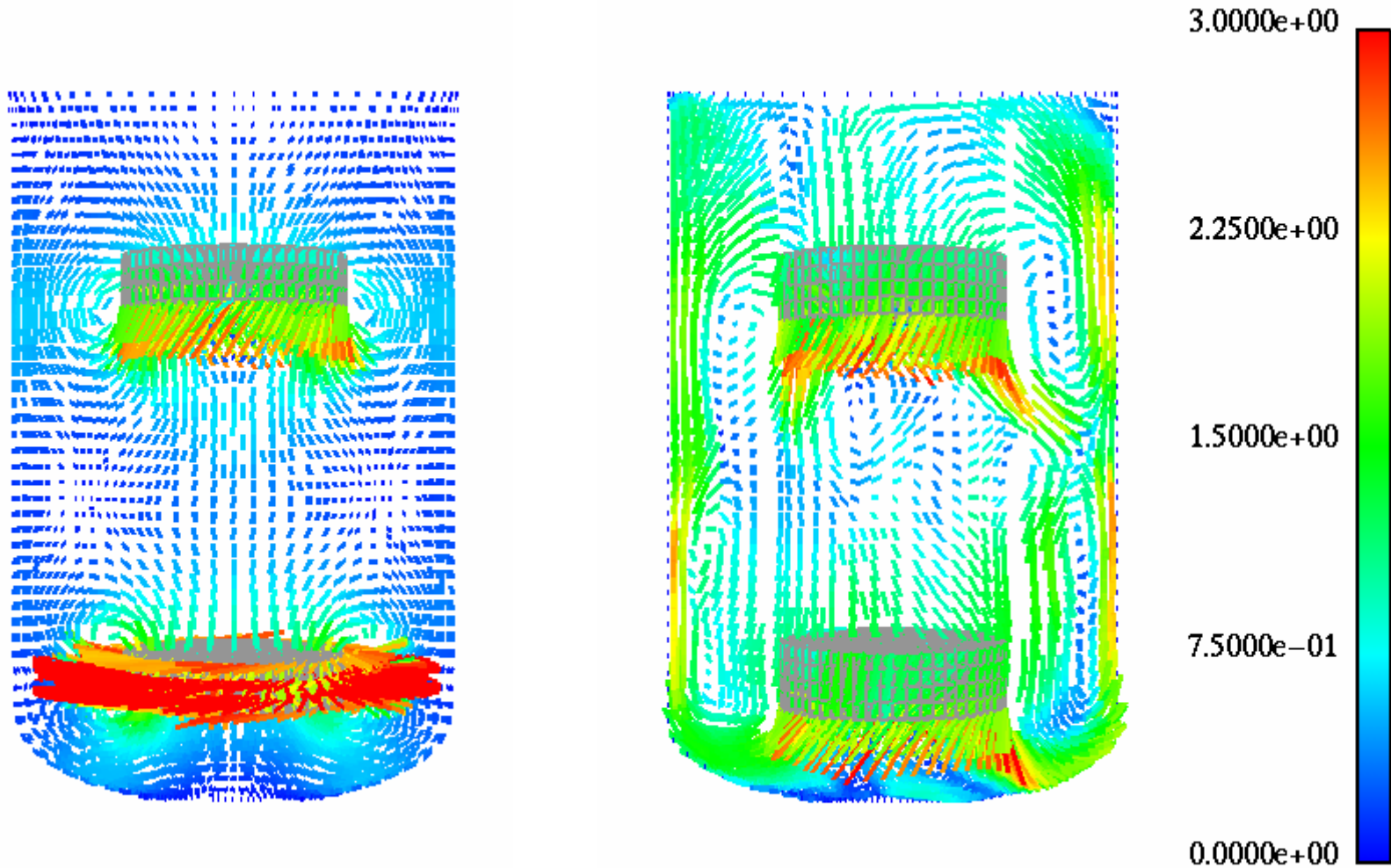

Laminar Flow in a Stirred Tank

Velocity Field Comparison for $Re = 20.4$

$$Re = \frac{ND^2 \rho}{\mu}$$

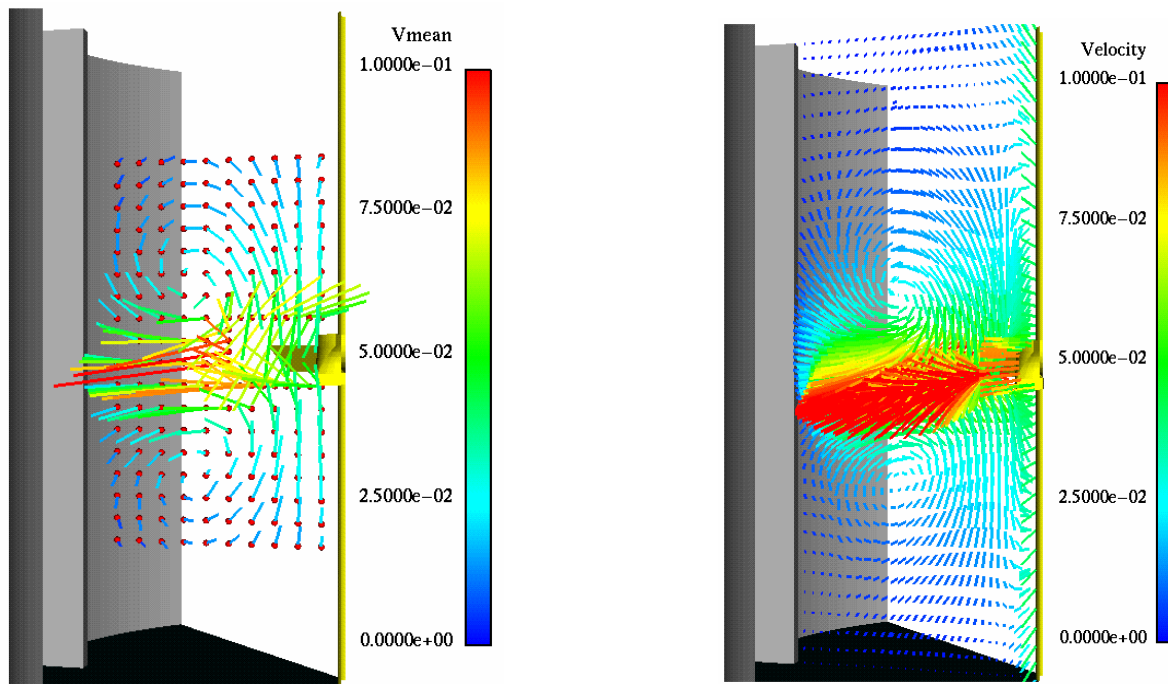

R. D. LaRoche & D. Choudhury
MIXING XV - Banff, Alberta, Canada, June 18-25, 1995

R.D. LaRoche, CFD in CRE IV
Barga, Italy, June 2005

Sliding-Mesh Stirred Tank Project

CPCFD Users Group 1994-96

- **Turbulent Stirred Tank**
 - $Re = 21505$, $N = 500$ rpm, $\mu = 1$ mPa•s
- **FLUENT v4.31**
 - 90° Tank Section
 - geometric symmetry (4 blades, 4 baffles)
 - k- ϵ RNG turbulence model
 - 70K Cells (38x37x49), Time-dependent sliding-mesh
 - No-slip boundary condition at impeller, walls, baffles
 - Liquid surface modeled as flat slip boundary
- **Dow Chemical Laser-Doppler Velocimetry Data for 4-blade Pitched Blade Turbine (Cassian Lee, 1994)**

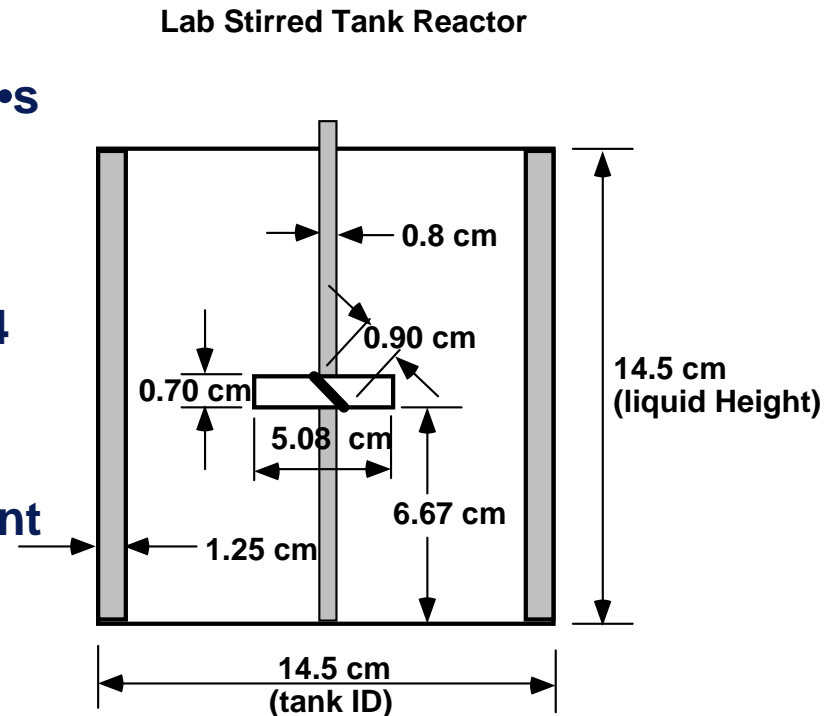

Baffles: 4 at 90° apart
Width: 1.25 cm
thickness: 0.3 cm
placed at the wall

Impeller: 4 blade, 45° PBT
blade width: 0.90 cm
thickness: 0.10 cm
diameter: 5.08 cm

Dow Chemical STR - FLUENT Sliding-Mesh Re=21505, RNG, 6 mm under 4-PBT in baffle plane

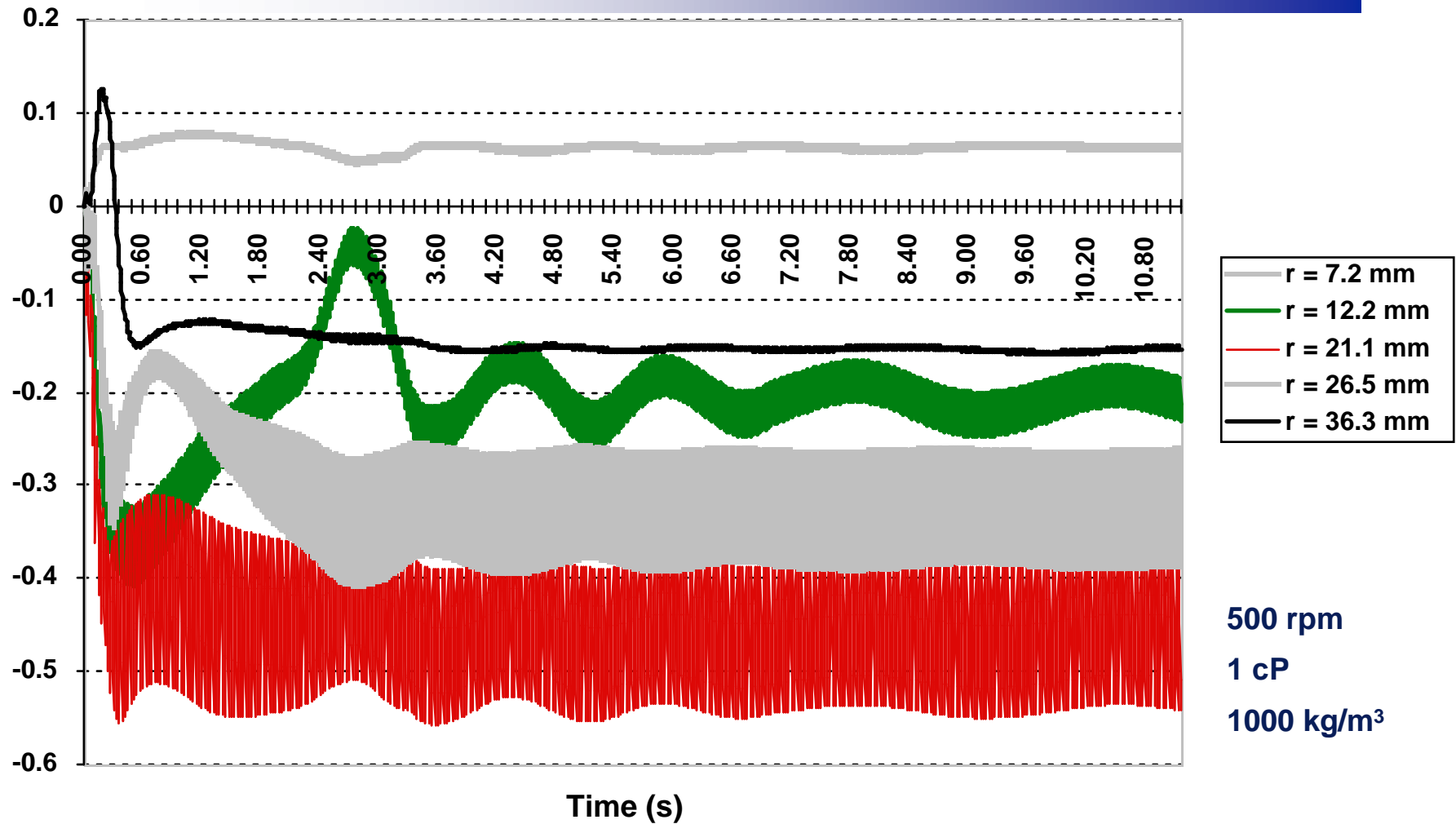

Velocity Vectors, $Re = 21505$

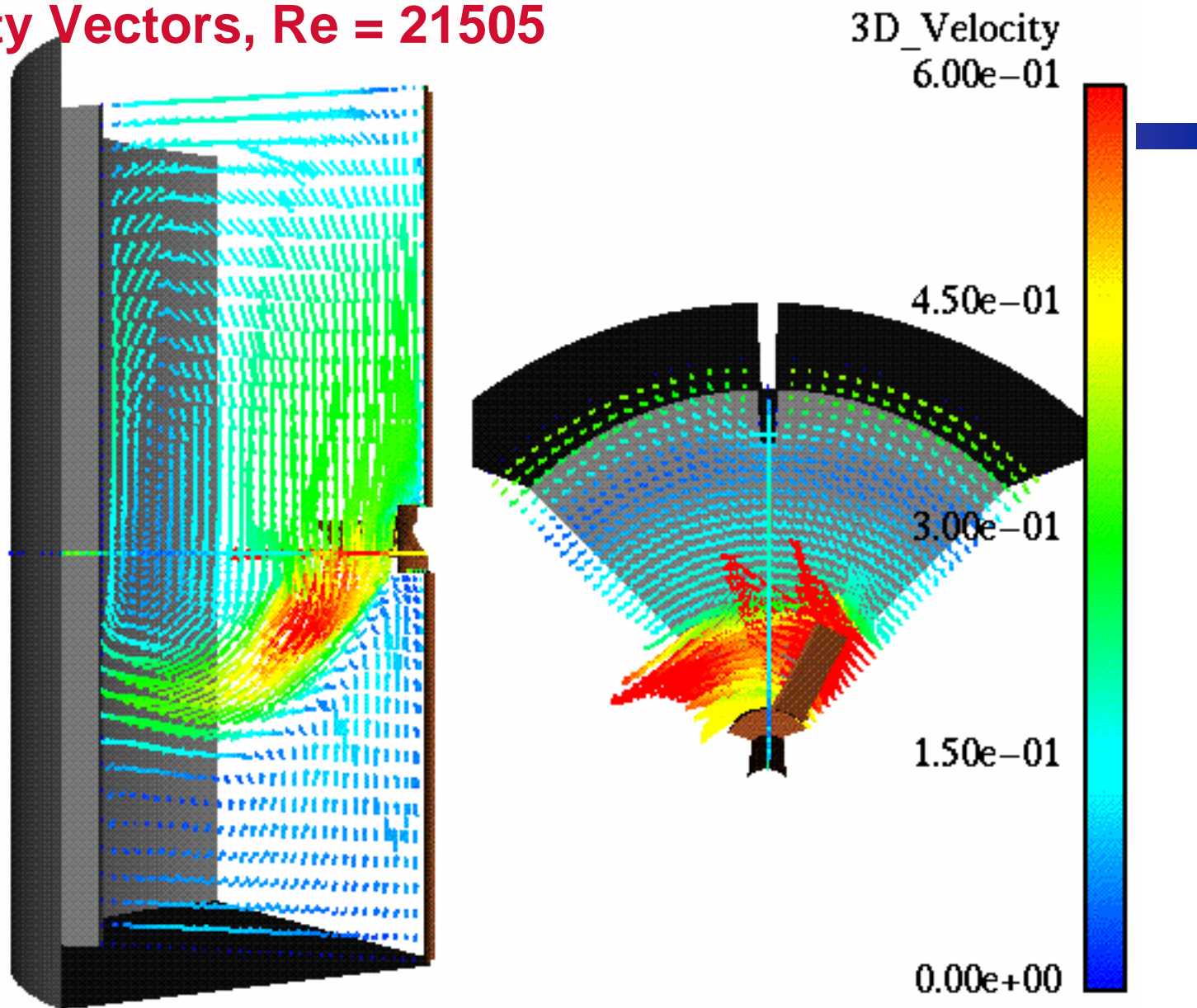

Sliding Mesh Stirred Tank: 1994 Statistics

- **Geometry and grid generation**
 - person-weeks
- **Startup Calculation Phase**
 - 90 revolutions
 - 20 timesteps/revolution (timestep=6.0e-3 s)
 - 80-160 Cray C90 CPU hours
- **Final Calculation Phase**
 - 1 revolution
 - 90 timesteps/revolution (timestep=1.33e-3 s)
 - 4 Cray C90 CPU hours
- **Comparison with LDV Data**
 - time-averaged velocities over 1/4 revolution (23 timesteps)

Calculated vs. Experimental Average Velocities 45PBT4, $Re = 21505$, Axial Station = $0.42H$

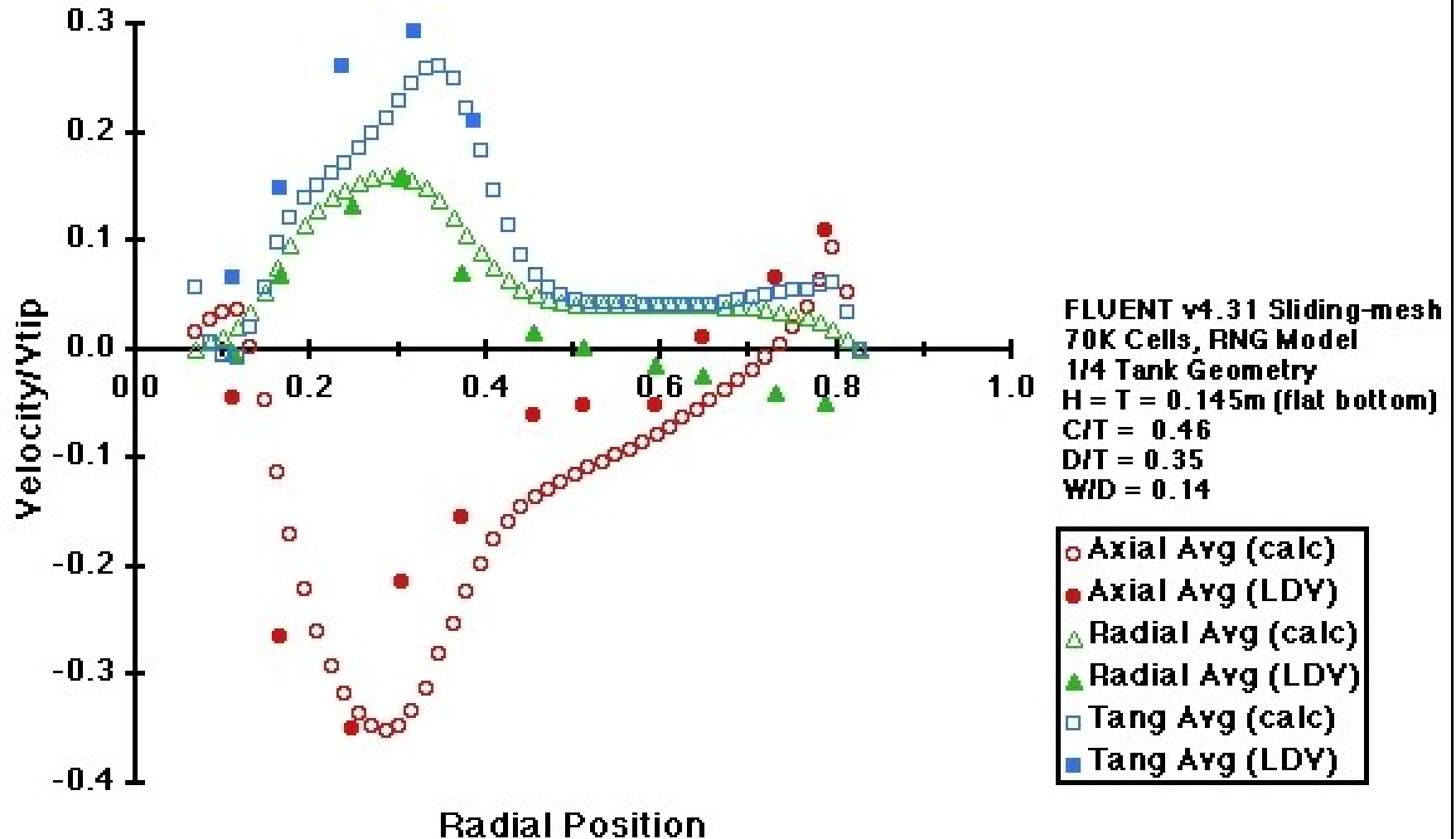

Turbulent Stirred Tank Analysis LaRoche, Liu & Andreasen (1999)

- **Flow & Turbulence Fields computed by MixSim1.0/Fluent 4.5**
 - Multiple Reference Frame (MRF), k- ϵ model
 - 220K Cells, 1/4 Geometry
 - Setup in less than 1 hour
 - ~8 cpu-hours
- **Lagrangian particle tracing using HyperTrace(tm)**
 - ~16 cpu-hours for 100K particles traced for 50 sec.
 - Scalable parallel application - 2 wallclock hours on 8 cpus

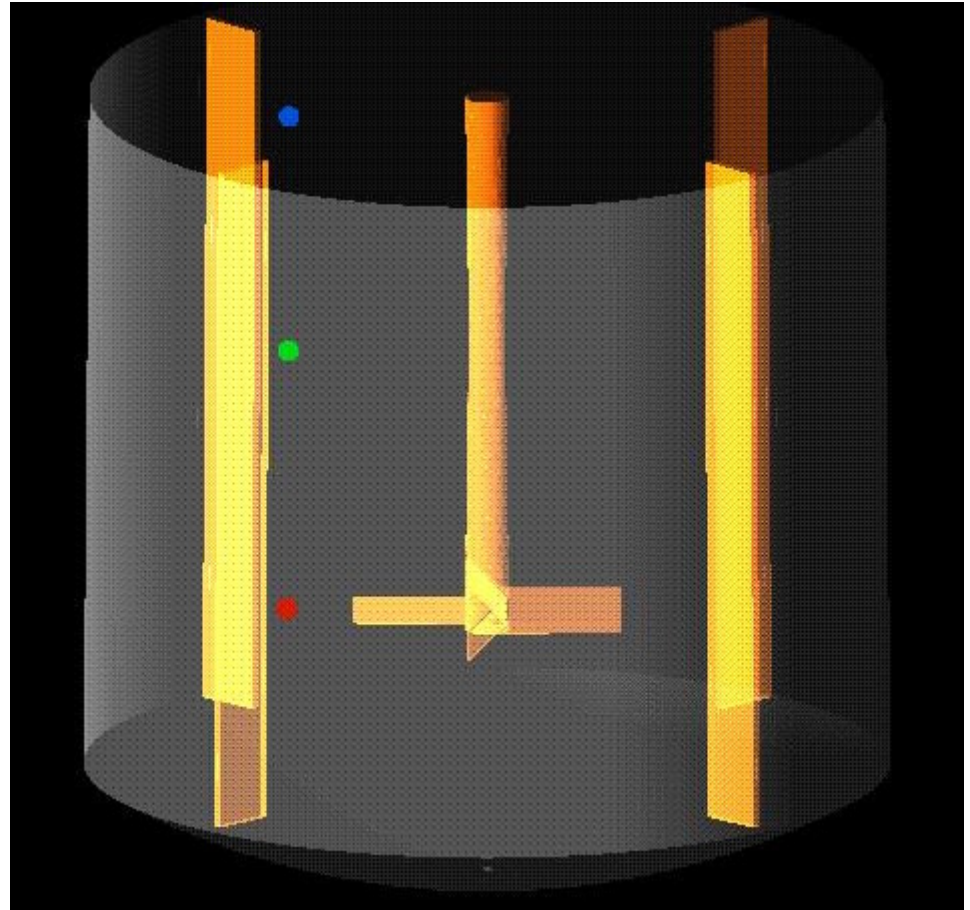

Effect of Tracer Injection Location

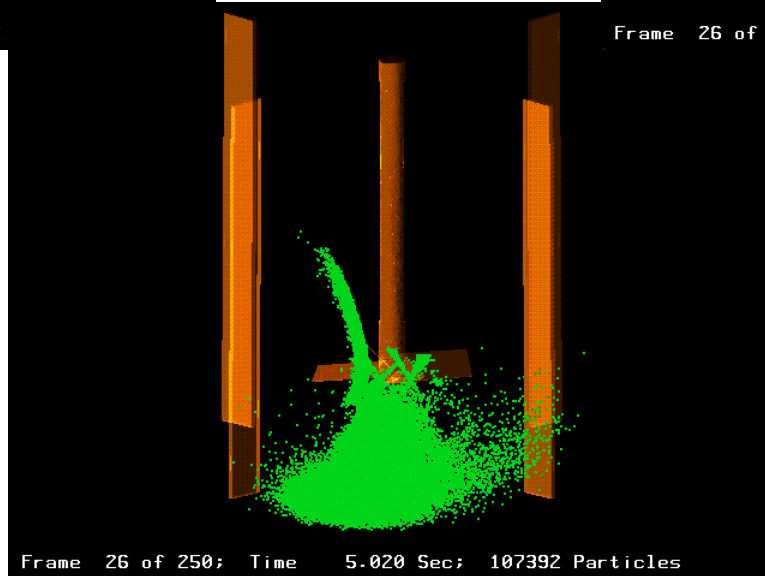
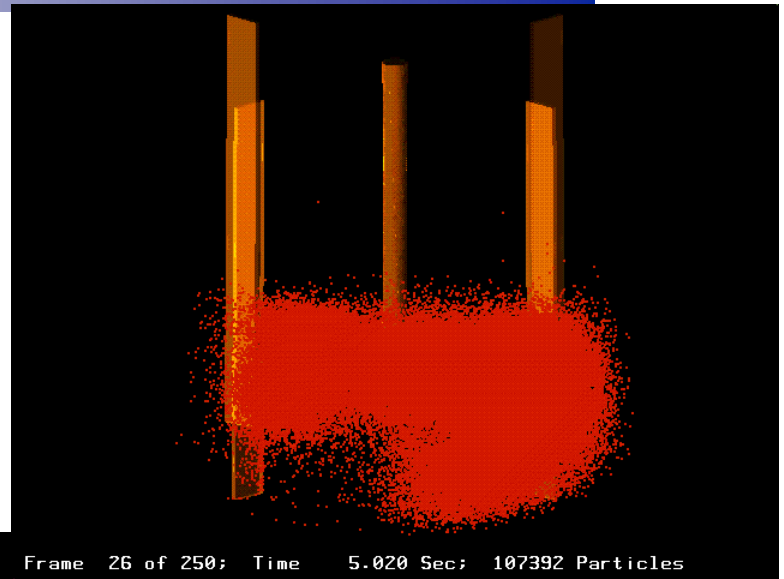
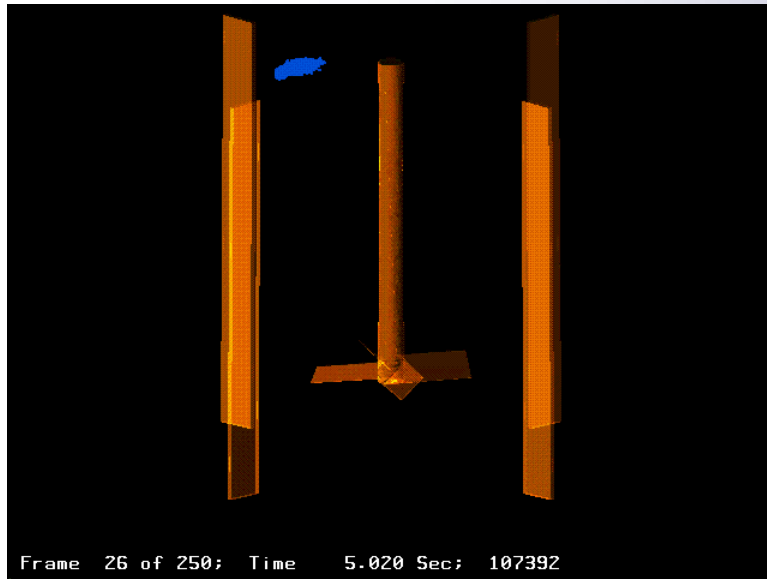

Stirred Tank Blendtime Comparisons

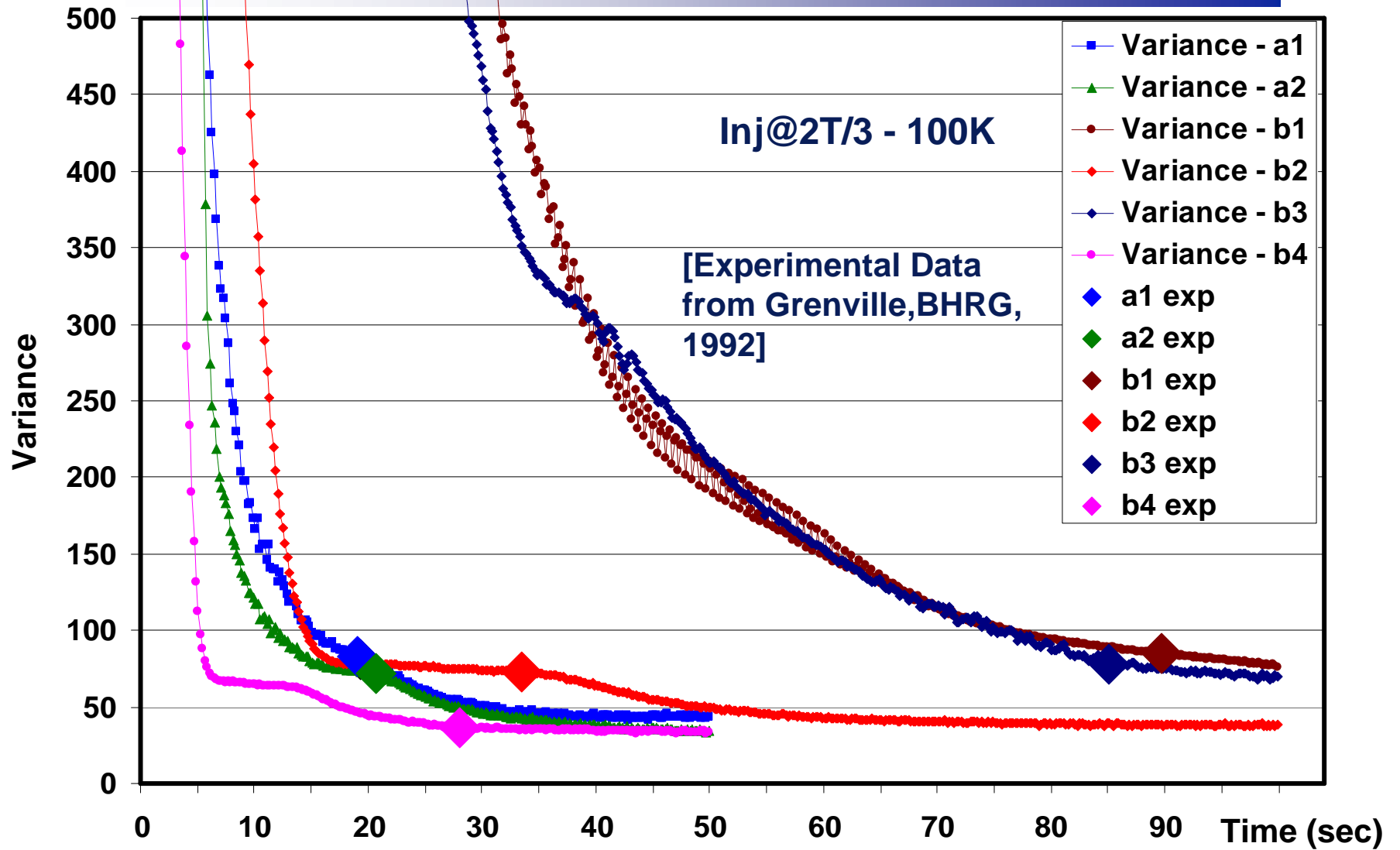

Power Number

- Measure Effects of Re, pitch/D, D_w/D , C/D to get P_o vs. Re plots

- Determined experimentally or using CFD

- Analogous to the friction factor in pipe flow

$$P_o = \frac{P}{\rho N^3 D^5}$$

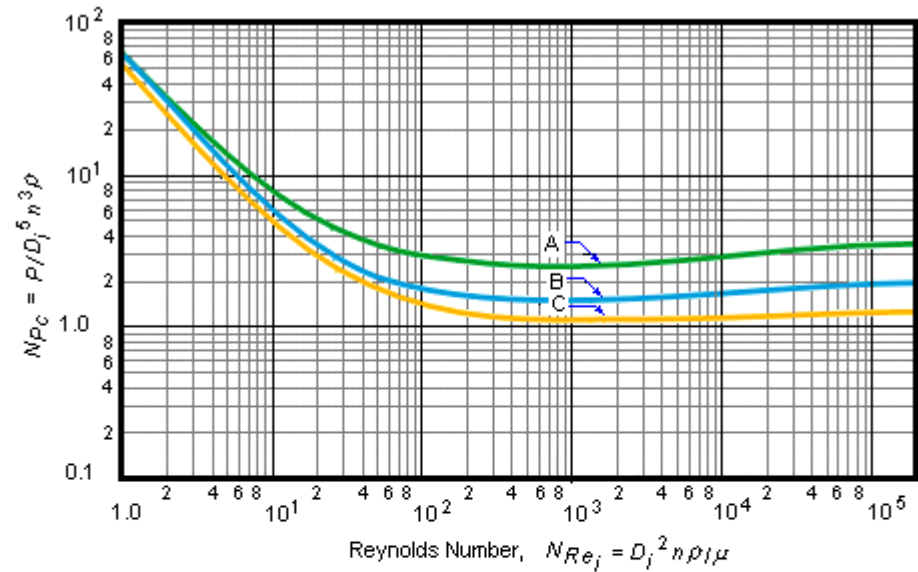

Curve A - Four, 90° blades, $b_j / D_j = 1/6$

Curve B - Four, 45° blades, $b_j / D_j = 1/6$

Curve C - Four, 45° blades, $b_j / D_j = 1/8$

Standard Dimensions

$$b_b = D_T / 12$$

$$D_j / D_T = 0.25 \text{ to } 0.7$$

$$Z_j / D_T \geq 0.6$$

$Z_{ib} = D_T / 6$ for flat bottom tanks. For dished head tanks, set bottom of the impeller at the bottom of the straight side and use Z_j as the length of the straight side.

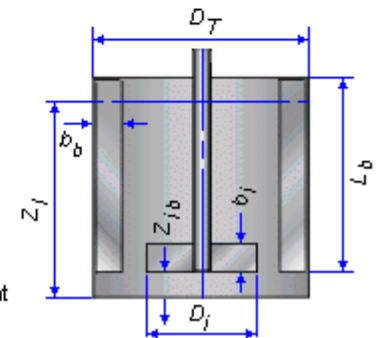

Blend Time

- How fast to get to Homogeneity?
- Measurements - Batch Stirred Tank
 - Color Change - somewhat arbitrary
 - Conductivity or pH - approach to steady state
 - Acid/Base Indicator Reactions
- Approach to Average Uniformity
 - 95% approach (or 5% of steady state)
 - Extrapolation along exponential decay curve

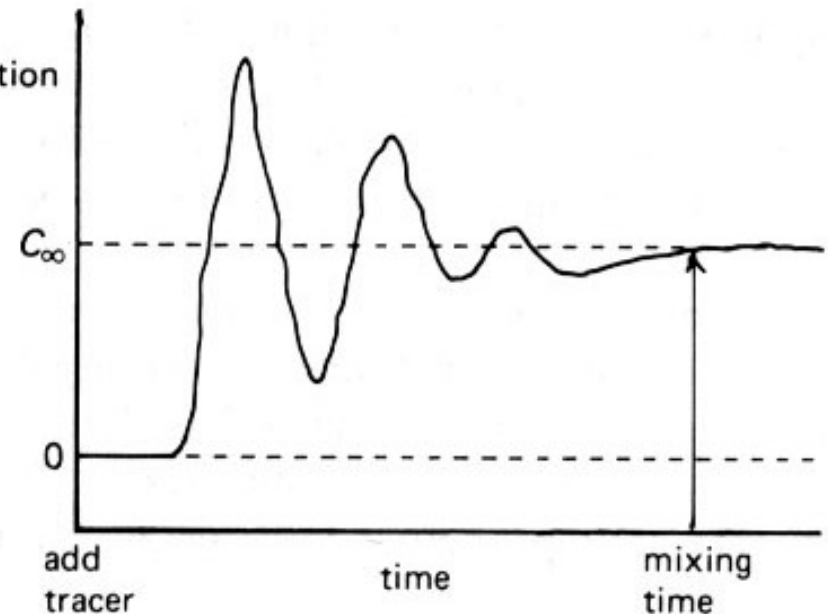

$$\Delta c = e^{(-k\theta)}$$

Blend Time Correlation

- **95% Mixing Time when $\Delta c=0.05$**

$$\theta_{95} = -k \ln(\Delta c) = -k \ln(0.05) = 3k$$

- **Turbulent Mixing Correlation (Ruzkowski & Grenville)**
 - Based on a wide range of impeller types and tank sizes
 - Quite a wide standard deviation for experimental results $\pm 30\%$

$$N\theta_{95} = \frac{5.4}{P_o^{1/3}} \left(\frac{T}{D} \right)^2 \quad \text{for } P_o^{1/3} \text{Re} > 6404$$

- **Why is so much effort spent on predicting blendtime?**
- **Not a particularly useful scale-up parameter**

Usefulness of the Power Number

- Estimate power imparted to the fluid by the impellers
- Many engineers may use Power per Tank Volume as a scale-up criterion
- Better Approach: ε - local power/mass (not average)
 - In stirred tanks, use power per impeller swept volume for ballpark estimate

$$\text{Assume } \varepsilon \propto \frac{P}{\rho V_{imp}} = \frac{P_o \rho N^3 D^5}{\rho \frac{\pi D^2}{4} D_w} = \frac{P_o N^3 D^5}{\frac{\pi D^2}{4} \alpha D} = \frac{P_o}{\frac{\pi \alpha}{4}} N^3 D^2 \Rightarrow \varepsilon \propto N^3 D^2$$

- Can be calculated directly from CFD
- Local ε is an important parameter in solids breakup, gas bubble breakup, mass transfer

Po Number - Effect of Mesh on Impeller Blade

| # | Name | Total # Fluid Cells | Mesh Type |
|---|------------------|---------------------|------------------|
| 1 | hybrid | 125936 | 90° Hybrid |
| 2 | hybrid-more-tets | 213305 | 90° Hybrid |
| 3 | pure-tet-coarse | 312781 | 360° Tetrahedral |
| 4 | pure-tet-fine | 942117 | 360° Tetrahedral |
| 5 | pure-hex-coarse | 85772 | 90° Hexahedral |
| 6 | pure-hex-fine | 197560 | 90° Hexahedral |

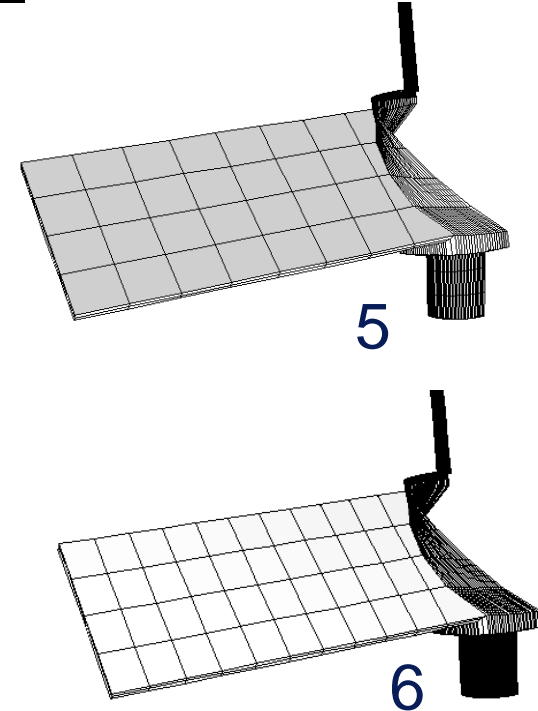
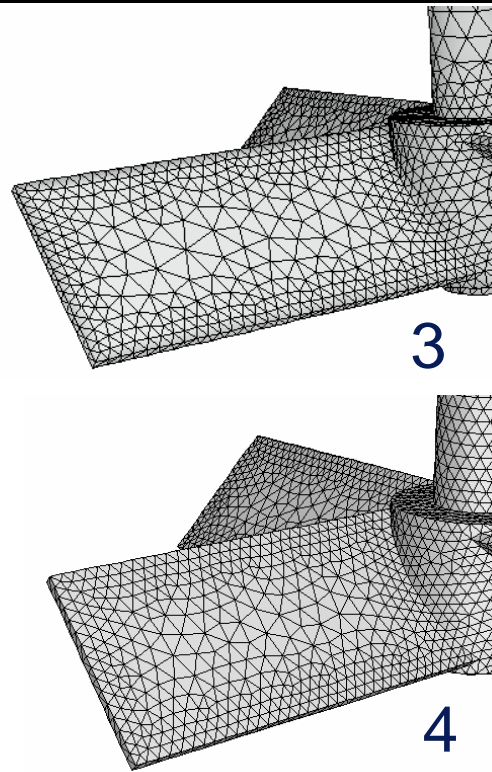
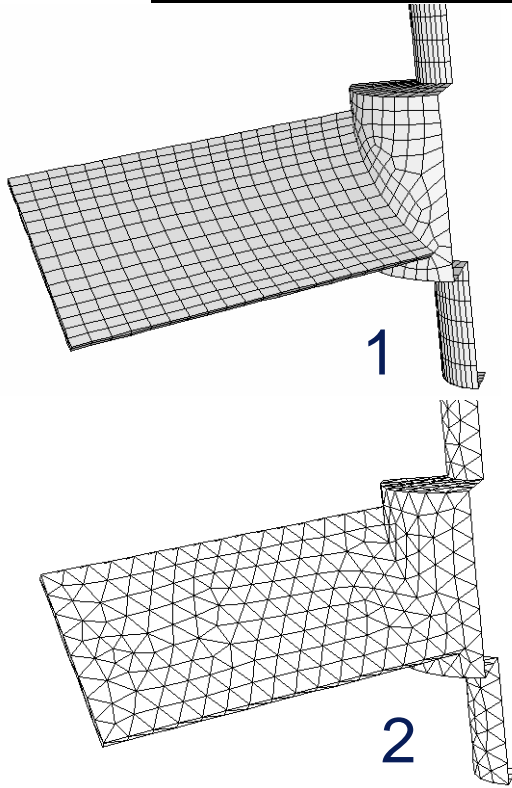

Power Numbers for Grid Dependence*

| Case | Computed N_p | % Error |
|-------------------------|----------------|------------|
| Pure-hex-coarse | 1.37 | 2.1 |
| Pure-hex-fine | 1.34 | 4.3 |
| Hybrid-original | 1.38 | 1.4 |
| Hybrid-more-tets | 1.36 | 2.9 |
| Pure-tet-coarse | 1.38 | 1.4 |
| Pure-tet-fine | 1.39 | 0.7 |

* Second order solutions, same solution scheme

Particle Statistics

- **Mammalian cell bioreactor**
 - Link to experimental observations of cell viability
- **Shed light on fluid environments that cells experience at different scales**
- **Opportunity to build additional models with particle tracking ODE when flow can be decoupled from cell processes**

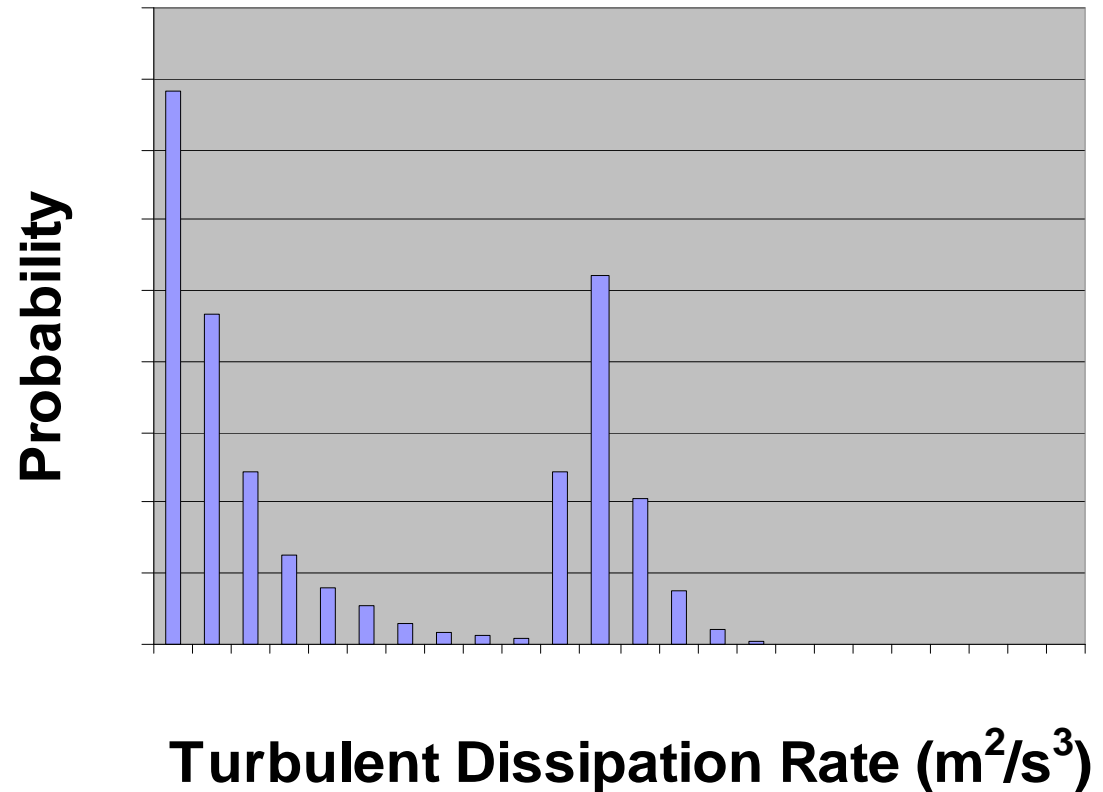

“Can You Simulate My Reactor?”

- **As engineers, why would we ask this question?**
- **First we must develop which “engineering question” needs to be answered**
- **Then decide what level of physics modeling is needed to answer the question**
- **Do you need 1% accuracy or do you need correct trends to choose between design alternatives?**
- **Build analysis approach in an incremental fashion**

“We Can’t Afford 3D Modeling, so We’ll Do 2D Anyway”

- **Example: 2D stirred tanks?**
 - Create more doubt from assumptions that it’s worth
 - 2D impellers & baffles?
- **Sympathize when there was a lack of (affordable) compute power and parallel software**
 - But maybe you should tackle the problem another way?
- **Extremely complicated physics with 2D models – does this make sense?**
- **Need to solve 3D before you knew whether you could justify simplifying to 2D!**
- **Design situation may be 2D flow, but pathological situation is 3D and/or transient!**
 - Example: slot coating flow
- **How about 3D, transient and simplified physics instead?**
 - Then you can add physics complexity as you go along
 - You are ever gaining insight

“Let’s jump in and solve this problem with CFD”

- **We tend to get enamored with high-tech tools that we forget our “engineering sense”**
- **Still useful to attack problem first as if you only had your calculator (or slide rule) and your books**
- **What are the standard design practices, theory and correlations?**
- **What are the known scaling rules?**

CFD as a Production Engineering Tool

- **Enabling Technologies**
 - Improved CAD tools
 - Automatic, unstructured meshing
 - Efficient, parallel software
 - Inexpensive parallel hardware
- **Better Physical Models**
 - Multiphase
 - Reacting Flow and Micromixing
 - Population Balance Methods
- **But We Must Not Lose the Ability to Build In Complexity Layer by Layer**

Optimistic But Some Concerns

- **Compute Resources**
 - **Most Companies Do Not Have Large Centralized Compute Facilities**
 - **Many Industrial Practitioners have access to small clusters (less than 8 cpus)**
 - **Large Compute Clusters Need Adequate Support Staff**

- **Engineers may forget to use all the tools**
 - **Engineering Fundamentals**
 - **Experimental data**
 - **Dimensionless numbers, time-scales**
 - **Design correlations**

Acknowledgments

- **Art Etchells – DuPont (retired)**
- **Richard Grenville – DuPont**
- **Jim Tilton - DuPont**

- **André Bakker – Fluent, Chemineer**
- **Liz Marshall – Fluent, Dartmouth**
- **Christine Wolfe – Fluent, DuPont**

- **Minye Liu – DuPont, P&G, Cray Research**

- **North American & European CPCFD User Groups**